

STROBE KIT CONTENTS

POWER SUPPLY

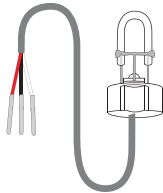

STROBE HEADS (x4pcs)

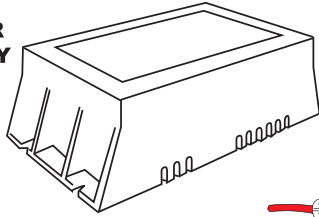

5 AMP FUSE

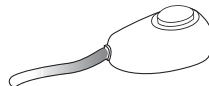

EZ-SWIT H

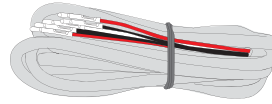

EXTENSION CABLES (4pcs)



PIN C CONNECTOR (8pcs)



SOCKET CONNECTOR (4pcs)

Strobe Kit Features:

- Multi-Voltage Input: **11-30VDC** - suits all vehicles.
- Waterproof - can install in engine compartment.
- Universal Xenon Bulbs - **no drilling required**.
- 15 Selectable Flash Patterns - for spectacular display.
- SSF Option - for connection with Car Alarm System.
- Low Power Option - for demo purpose.

STROBE KIT LAYOUT

Plan your kit layout before starting installation. This is a typical layout, and may vary depending on vehicle.

Follow Steps 1-5 for installation:

- 1 POWER SUPPLY WIRING
- 2 INSTALLING STROBE HEADS
- 3 WIRING EXTENSION CABLES
- 4 EZ-SWITCH FUNCTIONS
- 5 OPTIONAL WIRING

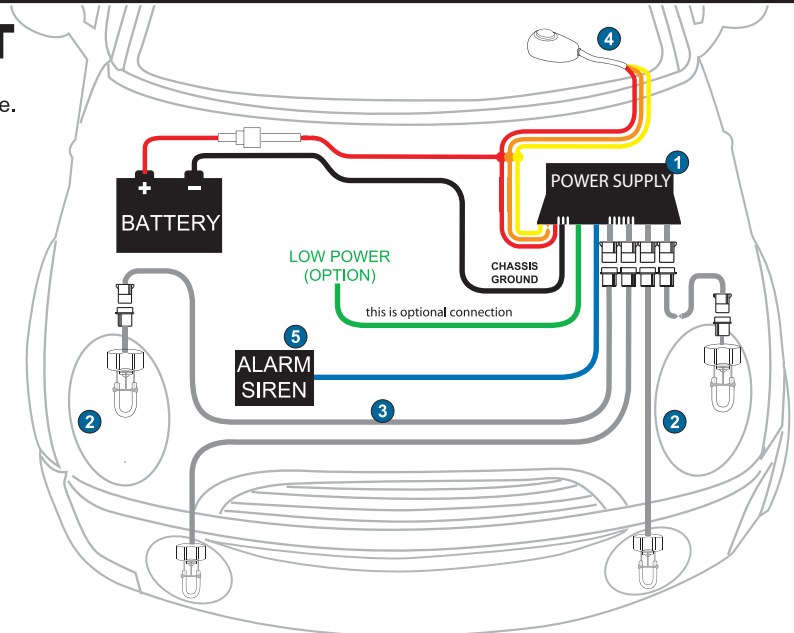

Warning: Before making any connections to the vehicle wiring, always disconnect the battery negative terminal.

1 POWER SUPPLY WIRING

The POWER SUPPLY is waterproof, and can be mounted in areas exposed to water. However, it is recommended to mount in an area where it is not exposed to excessive heat during normal operation of the vehicle.

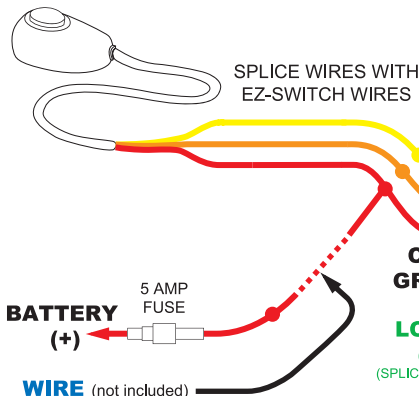

WIRE (not included)
Note: Use the correct size wire to connect to battery (+). The length of the wires determines the size needed:
 1 to 7 ft. use 18AWG wire
 7 to 14 ft. use 16AWG wire

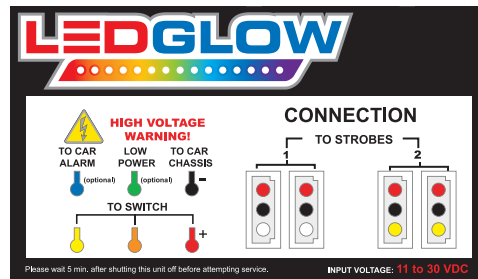

Warning: This is a high voltage device, do not touch or remove strobe light head while in operation. Wait at least 5 minutes after disconnecting from its power source before starting work or troubleshooting.

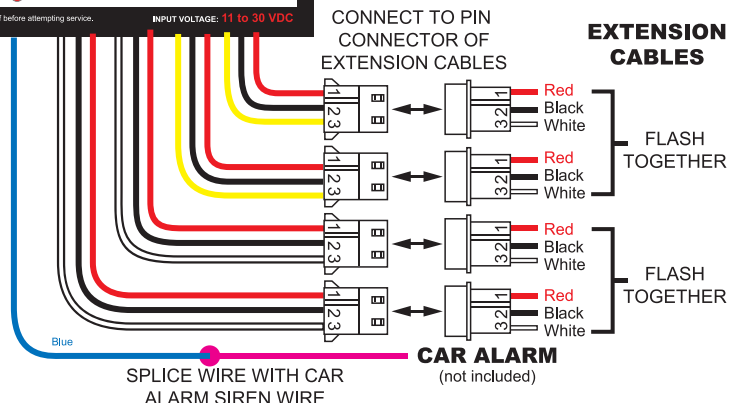

2 INSTALLING STROBE HEADS

The STROBE HEADS can be easily installed in the auxiliary lights by removing the existing bulbs.

FOR H3 INSTALLATION:

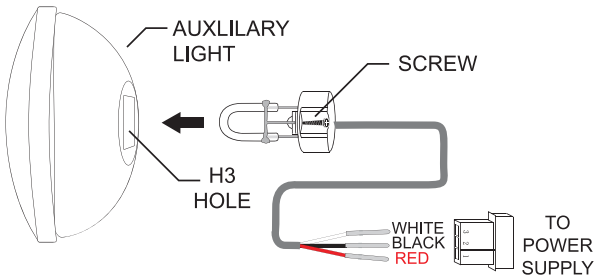

1. remove existing H3 bulb.
2. push strobe head in the hole.
3. secure strobe head with screw.
4. insert wire pins to connector.

3 WIRING EXTENSION CABLES

Insert wires with SOCKETS into the proper holes in the connector

Hole 3	WHITE WIRE
Hole 2	BLACK WIRE
Hole 1	RED WIRE

Insert wires with PINS into the proper holes in the connector

Hole 3	WHITE WIRE
Hole 2	BLACK WIRE
Hole 1	RED WIRE



4 EZ-SWITCH FUNCTIONS

The EZ-SWITCH provides complete flash pattern selection; mount around dash area.

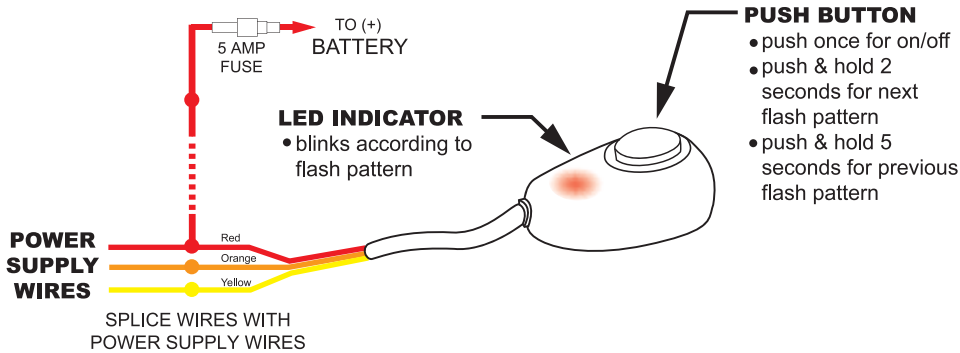

Flash Patterns	
0	DEMO CYCLE - display all flashing patterns
1	QUAD, (1 ALT 2)
2	QUINT, (1 ALT 2)
3	DOUBLE, (1 ALT 2)
4	TWIN DOUBLE, (1 ALT 2)
5	MEGA, (1 ALT 2)
6	QUINT --> MEGA, (1 ALT 2)
7	DOUBLE --> QUINT, (1 ALT 2)
8	DOUBLE DELAY, (1 ALT 2)
9	QUAD DELAY, (1 ALT 2)
10	WAVE - fast to slow cycle, (1 ALT 2)
11	DUAL: WAVE - fast to slow cycle, (1 & 2)
12	DUAL: DOUBLE, (1 & 2)
13	DUAL: QUINT, (1 & 2)
14	DUAL: 1 --> 3 --> 5 Flash, (1 & 2)
15	DEF JAM MODE

Note: Flash Pattern DEMO CYCLE displays all flashing patterns. This is ideal for demo cars at shows or in showrooms.

*ALT = Alternating Strobe Head
*DUAL = Simultaneous Strobe Head

5 OPTIONAL WIRING

SSF The **S**mart **S**ecurity **F**unction allow the strobe kit to be synchronized with the car alarm. When the alarm is triggered, the ultra bright strobes will flash; creating an immense warning effect. The strobes can also be activated via the 'seek/panic' button for car search in big parking lots.

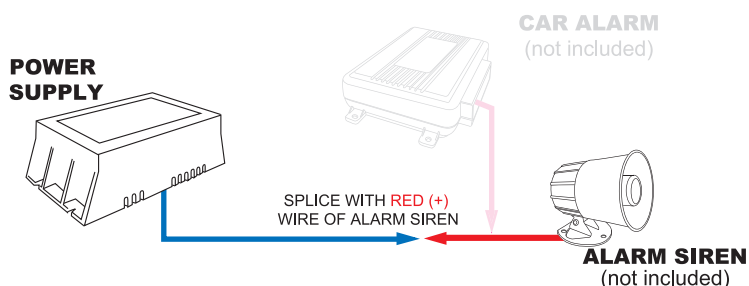

LOW POWER The LOW POWER function is used to decrease brightness of the strobes. This is useful for demo cars in display at shows or in showrooms where it might not be possible to strobe at full brightness.

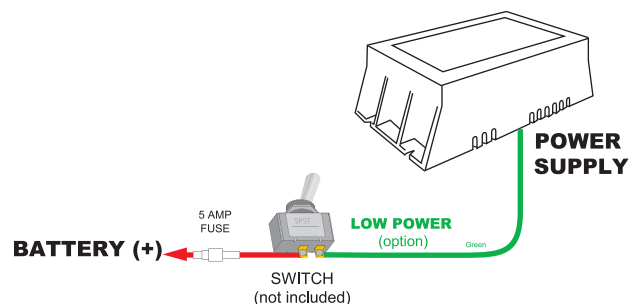

SPLICE GREEN WIRE WITH RED (+) WIRE FOR LOW POWER. OR INSTALL A SWITCH TO TURN ON (low power) & OFF (high power).