

4pc Million Color 6 Seater Golf Cart Lighting Kit

⚠WARNING: Please check your state and local laws before installing this LED lighting kit. Every state has different policies and procedures in place regarding aftermarket vehicle accessories. LEDGlow is not responsible for any fines that you may receive while using this lighting kit. This kit is for off-road use only.

We recommend having this kit installed by a licensed professional. The improper installation of this kit voids all warranties.

PLEASE READ THE FOLLOWING INSTRUCTIONS THOROUGHLY BEFORE INSTALLING AND OPERATING THIS LED GOLF CART KIT.

Golf Cart Kit Includes:

- (2) 18" Flexible Tubes
- (2) 46" Flexible Tubes
- Control Box
- Underbody Junction Box
- Wireless Remote
- Self-Tapping Screws
- Zip-Ties

Golf Cart Kit Installation:

1. Temporarily power the kit with any 12 volt source to ensure proper functionality before installation. Connect the red wire to the positive (+) terminal and the black wire to any reliable ground source or negative (-) terminal.
2. Arrange the tubes out on the ground the way you plan on installing them and connect them to the junction box. After powering the kit and determining it is functioning properly, remove the kit from power.
3. Disconnect the negative side of the golf cart's battery.

➤ **OPTIONAL STEP:** Raise and support the golf cart if necessary.

4. Clean the proposed mounting surfaces with an alcohol prep pad. The mounting surface should be between 45 and 85 degrees Fahrenheit to achieve the strongest bonding results from the double-sided adhesive tape.

⚠WARNING: The surface area must be free of all oils, moisture, dirt and wax for the supplied adhesive tape to bond and adhere to the installation surface properly.

🔧 **TECH TIP:** To achieve the strongest bond between the tape on the lighting tubes and the golf cart, you can use Adhesion Promoter, which is sold separately from your kit at www.LEDGlow.com. Once the lighting tubes are in place make sure they are permanently secured using screws and/or wire ties.

5. When installing the underbody or wheel well lighting tubes, ensure plenty of clearance from heat and moving parts. The lighting tubes are flexible and can be contoured. When mounting the tubes be sure to use a combination the supplied double sided tape, screws and zip-ties.
6. Mount the front 18" lighting tube with the wire facing the driver's side of the cart.
7. Mount the side 46" lighting tubes with the wires facing the front of the cart.
8. Mount the rear 18" lighting tube with the wire facing the passenger side of the cart.
9. Mount the junction box under the seat of the golf cart in a dry location.
10. Starting with the rear tube, run the wires to the junction box. Make sure to secure the wires tightly when going around any suspension parts and exhaust using the included zip-ties. Wires must be at least 10" from the exhaust, and away from any suspension parts. If a wire is pinched, the kit may malfunction and could void the warranty. Run the underbody wires along the golf cart frame in addition any optional wheel well and interior wires and make sure everything is tightly secured. Ensure that all connections are secure.

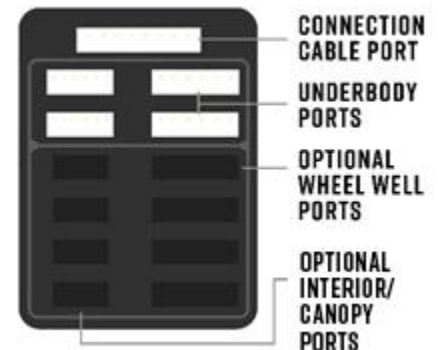
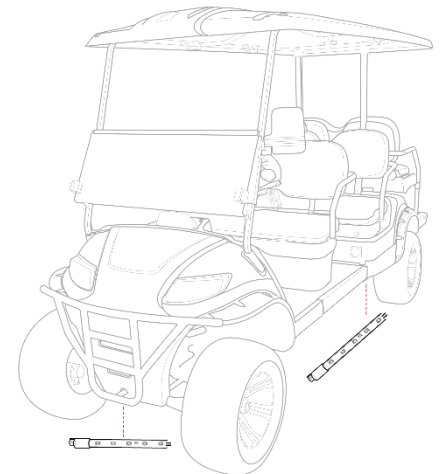

11. Mount the control box under the seat or in the glove box of the golf cart making sure it is kept dry using the included adhesive tape.

CAUTION: The junction and control boxes **MUST** be mounted away from heat, moisture, and the elements.

12. Run the connection cable from the junction box to the control box and ensure that the connectors are secure.

Connecting Power to Electric Golf Carts:

This Million Color Golf Cart Lighting Kit was designed to be powered by a 12 volt system. If you are running a 36 or 48 volt system, a Golf Cart Battery Voltage Reducer is required. This Reducer can be purchased at LEDGlow.com. If you are using an existing voltage reducer or another brand, be sure to check the output of the reducer and make sure it is not over 12 volts. Failure to do this could result in kit failure. The steps below will guide you through the process of installing your Million Color LED Golf Cart Underbody Lighting Kit using a Golf Cart Battery Voltage Reducer.

1. If you are unsure of the voltage in your golf cart, temporarily reconnect the negative side of the battery and verify voltage with a multimeter before connecting the kit to the golf cart.
2. The Golf Cart Battery Voltage Reducer can accept an input voltage of 15-60 volts, while outputting 12 volts at a max of 5 amps. This allows you to connect to any power source on the cart safely. The light kit will draw power evenly from all batteries, prolonging the life of every battery in the cart. Switch your golf cart to TOW mode (if available) and turn the key switch to OFF so the golf cart is powered down.
3. Using a multimeter, test the voltage of the batteries to which you will be installing the Golf Cart Battery Voltage Reducer. Because an electric golf cart requires significant current for standard operation, several batteries are typically wired in series in order to achieve the power needed. It is extremely important to test the voltage of the chosen power source prior to installing the Golf Cart Battery Voltage Reducer as failure to install it correctly could lead to overheating and complete failure of the voltage reducer. This could also potentially damage components of the golf cart and/or light kit.
 - A 36 volt golf cart will typically have (6) 6 volt batteries. **(Image A)**
 - A 48 volt golf cart could be wired in several different configurations, such as:
 - (8) 6 volt batteries. **(Image B)**
 - (6) 8 volt batteries. **(Image C)**
 - (4) 12 volt batteries. **(Image D)**

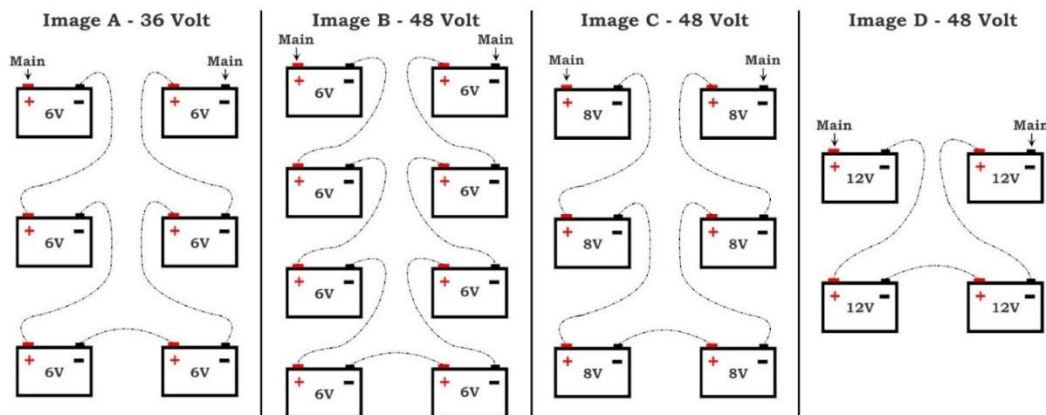

4. Using a multimeter, test each individual battery's voltage. To do this, hold one lead from the multimeter to the negative post of the main battery. Then, hold the other lead from the multimeter to the positive post of each battery, taking note of the voltage displayed on the multimeter at each battery. The voltage reducer will be connected to both the main positive and negative battery posts where voltage is the greatest. This will ensure an even draw of power across all batteries.
5. Disconnect the main negative terminal of the golf cart's battery.
6. Find a reliable, flat metal surface to mount the Golf Cart Battery Voltage Reducer using screws and double sided tape, away from any heat or moving parts. **The Golf Cart Battery Voltage Reducer may reach high temperatures, so it is important that this is not installed in direct contact with any plastic parts of the golf cart.**

CAUTION : Double check the Voltage Reducer instructions and be sure that you connect to the correct Input and output wires. Wire colors could vary by production date.

7. Using wire strippers, strip the lead wires of the Golf Cart Battery Voltage Reducer exposing 1/4" of bare wire.
8. Connect the red wire from the input side of the Golf Cart Battery Voltage Reducer to the main positive terminal of the battery on the golf cart using an eyelet, spade, or similar connector (not included).
9. Connect the black wire from the input side of the Golf Cart Battery Voltage Reducer to the main negative terminal of the battery on the golf cart using an eyelet, spade, or similar connector (not included).
10. Connect the yellow wire from the output side of the Golf Cart Battery Voltage Reducer to the positive wire of the lighting accessory that you are installing to the golf cart using a butt connector or a similar connector (not included). If possible, soldering the wires is recommended to ensure a secure connection.
11. Connect the black wire from the output side of the Golf Cart Battery Voltage Reducer to the ground wire of the lighting accessory that you are installing to the golf cart using a butt connector or similar connector (not included).
12. Reconnect the main negative terminal of the golf cart's battery and switch your cart back to RUN mode (if available).

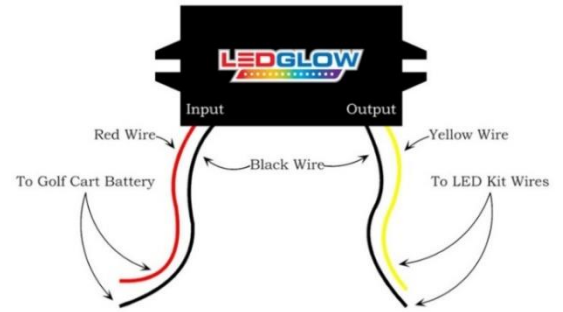

Connecting Power to Gas Engine Carts:

1. Connect the red wire from the control box to a positive 12 volt source. If you are unsure of available voltage in your golf cart, verify voltage with a multimeter before connecting the kit to the golf cart. Note: If you need to extend the power wires, be sure to use 16 or 18 gauge automotive grade wire. If you are running the power wire to the battery and must go through metal, use an existing grommet or drill a hole and add a new grommet, which are available at any auto parts store. Be sure to reinstall the fuse within 6" of the power source. If you connect the power wire to a switched 12 volt source, then it will not remember the previous color and pattern to which it was last set.
2. Connect the black wire from the control box to a reliable ground source, grounding block, or directly to the negative terminal of the battery.

Testing Operation of the Kit:

1. Lower the golf cart if it was raised and test your new LEDGlow Million Color LED Golf Cart Underbody Kit. Cycle through the colors and modes to ensure full functionality by pressing the buttons on the control box or by using one of the included remotes.
2. With the golf cart on the ground, turn the steering wheel as far as it can go in both directions to ensure that there will be no tubes and/or wires coming in contact with the tires. **If a tube or wire is damaged by the tire, the warranty will be voided.**

Control Box & Wireless Remote Functions:

Power Button	On/Off
Mode Button	Solid Illumination, 7 Running Modes, Pulse Mode, 3 Scan Modes, 3 Strobe Modes, 3 Fade Modes, S.O.S Mode, 4 Music Modes, Demo Mode
Color Button	Red, Hot Pink, Pink, Purple, Orange, Yellow, Green, Teal, Blue, White, Color Cycle, Color Fade
Speed Button	5 Speed Levels

- **Enable Auto On/Off Function:** Turn the kit off. Press and hold down **Mode** and **Color** buttons on the control box. After the teal color lights up, turn on the kit and test for functionality.
- **Disable Auto On/Off Function:** Turn the kit off. Press and hold down **Mode** and **Speed** buttons on the control box. After the Orange color lights up, turn on the kit and test for functionality.

Adding or Replacing a Wireless Remote:

1. Your kit is already pre-programmed for the included wireless remotes. This setup is only needed when replacing an existing remote or when adding more wireless remotes to your system. You can program up to 2 wireless remotes for 1 control box.
2. In order to program the remote to the control box, you must turn the kit off.
 - Press and hold the "Mode" button on the control box and any button on the wireless remote simultaneously for 5-7 seconds. The LEDs on the kit will illuminate green if successful. Test the operation with the remote.



Tech Support 856-768-5700 Ext. 2 • TechSupport@LEDGlow.com

ONE YEAR NON-TRANSFERRABLE LIMITED WARRANTY AND DISCLAIMER

LEDGlow Lighting, LLC ("LEDGlow") warrants to the original retail consumer purchaser, and not any other purchaser or subsequent owner, that this Product will be free from defects in material or workmanship for a period of **one (1) year** from the purchase date. **This warranty does not cover any Product that is (1) installed incorrectly, or (2) damaged by collisions, vandalism, other accidents, or similar causes.**

For a period of **one (1) year** from the date of purchase, at no charge to the Purchaser, LEDGlow will repair or replace this Product if it is determined by LEDGlow to be defective. After the warranty period, the Purchaser must pay all charges for parts and labor.

Coverage under this warranty is only valid within the United States, including its territories, as well as in certain other countries. Purchasers should check our website, www.LEDGlow.com, to determine the warranty coverage in the countries in which they are located.

LEDGlow does **not warrant the installation** of the Product, which is the sole responsibility of the Purchaser. Installation should be done by licensed professionals. Improper installation may cause damage to the Product and any vehicle in which it is installed, and may cause burns and electrical injury to individuals. LEDGlow's warranty does not cover any expenses incurred in removing Products that are defective or re-installing replacement Products in their place.

During the warranty period, to have the Product repaired or replaced, the Purchaser must return the Product, freight prepaid by the Purchaser, to LEDGlow (but for customers in the contiguous United States, LEDGlow will pay the shipping charges if any Product fails during the first thirty (30) days after purchase). The Product must be returned in its original carton or in a similar package affording an equal degree of protection. LEDGlow will return the repaired or replaced Product, freight prepaid, to the Purchaser. LEDGlow does not provide Purchasers with temporary replacement units during the warranty period or at any other time.

This limited warranty is non-transferrable and will automatically terminate if the original retail consumer purchaser resells the Product or transfers the vehicle on which the Product is installed. An "original retail consumer purchaser" is a person who originally purchases the Product, or a gift recipient of a new Product that is in its original packaging and unopened.

This limited warranty is subject to all of the following terms and conditions:

TERMS AND CONDITIONS

1. NOTIFICATION OF CLAIMS; WARRANTY SERVICE: IF PURCHASER BELIEVES THAT A PRODUCT IS DEFECTIVE IN MATERIAL OR WORKMANSHIP, WRITTEN NOTICE WITH AN EXPLANATION OF THE CLAIM SHALL BE GIVEN PROMPTLY BY PURCHASER TO LEDGLOW. ALL WARRANTY CLAIMS MUST BE MADE WITHIN THE WARRANTY PERIOD, AND ANY PRODUCTS RETURNED TO LEDGLOW MUST BE SHIPPED IN ACCORDANCE WITH LEDGLOW'S PROCEDURES (INCLUDING USE OF RMA NUMBERS SUPPLIED BY LEDGLOW AFTER NOTIFICATION). THE REPAIR OR REPLACEMENT OF ANY PRODUCT OR PART THEREOF SHALL NOT EXTEND THE ORIGINAL WARRANTY PERIOD. THE SPECIFIC WARRANTY ON THE REPAIRED PART ONLY SHALL BE IN EFFECT FOR A PERIOD OF NINETY (90) DAYS FOLLOWING THE REPAIR OR REPLACEMENT OF THAT PART, OR THE REMAINING PERIOD OF THE PRODUCT WARRANTY, WHICHEVER IS GREATER.

2. EXCLUSIVE REMEDY; ACCEPTANCE: PURCHASER'S EXCLUSIVE REMEDY AND LEDGLOW'S SOLE OBLIGATION IS TO SUPPLY (OR PAY FOR) ALL LABOR NECESSARY TO REPAIR ANY PRODUCT FOUND TO BE DEFECTIVE WITHIN THE WARRANTY PERIOD AND TO SUPPLY NEW OR REBUILT REPLACEMENTS FOR DEFECTIVE PARTS. LEDGLOW WILL REFUND THE PURCHASE PRICE FOR SUCH PRODUCT ONLY IF REPAIR OR REPLACEMENT FAILS TO REMEDY THE DEFECT. PURCHASER'S FAILURE TO MAKE A CLAIM AS PROVIDED IN PARAGRAPH 1 ABOVE OR CONTINUED USE OF THE PRODUCT SHALL CONSTITUTE AN UNQUALIFIED ACCEPTANCE OF SUCH PRODUCT AND A WAIVER BY PURCHASER OF ALL CLAIMS THERETO.

3. EXCEPTIONS TO LIMITED WARRANTY: LEDGLOW SHALL HAVE NO OBLIGATION TO PURCHASER WITH RESPECT TO ANY PRODUCT THAT IS SUBJECT TO ANY OF THE FOLLOWING: ABUSE, IMPROPER USE, NEGLIGENCE, ACCIDENT, MODIFICATION, FAILURE TO FOLLOW THE OPERATING PROCEDURES OUTLINED IN THE USER'S MANUAL, FAILURE TO FOLLOW THE MAINTENANCE PROCEDURES IN THE SERVICE MANUAL FOR THE PRODUCT, ATTEMPTED REPAIR BY NON-QUALIFIED PERSONNEL, OPERATION OF THE PRODUCT OUTSIDE OF THE PUBLISHED ENVIRONMENTAL AND ELECTRICAL PARAMETERS, OR IF THE PRODUCT'S ORIGINAL IDENTIFICATION (TRADEMARK, SERIAL NUMBER) MARKINGS HAVE BEEN DEFACED, ALTERED, OR REMOVED. LEDGLOW EXCLUDES FROM WARRANTY COVERAGE PRODUCTS SOLD AS IS AND/OR WITH ALL FAULTS. LEDGLOW ALSO EXCLUDES FROM WARRANTY COVERAGE ANY CONSUMABLE ITEMS SUCH AS FUSES AND BATTERIES.

All software and accompanying documentation furnished with, or as part of the Product is furnished "AS IS" (i.e., without any warranty of any kind), except where expressly provided otherwise in any documentation or license agreement furnished with the Product.

4. PROOF OF PURCHASE; REGISTRATION: The Purchaser's dated bill of sale must be retained as evidence of the date of purchase and to establish warranty eligibility. Registration of any Product or of this limited warranty is voluntary, and failure to register will not diminish any rights available under this warranty.

DISCLAIMER OF WARRANTY

EXCEPT FOR THE FOREGOING WARRANTIES, LEDGLOW HEREBY DISCLAIMS AND EXCLUDES ALL OTHER WARRANTIES, EXPRESS OR IMPLIED, INCLUDING, BUT NOT LIMITED TO ANY IMPLIED WARRANTIES OF MERCHANTABILITY, FITNESS FOR A PARTICULAR PURPOSE, OR ANY WARRANTY WITH REGARD TO ANY CLAIM OF INFRINGEMENT THAT MAY BE PROVIDED IN SECTION 2-312(3) OF THE UNIFORM COMMERCIAL CODE OR IN ANY OTHER STATE STATUTE.

LIMITATION OF LIABILITY

THE LIABILITY OF LEDGLOW, IF ANY, AND PURCHASER'S SOLE AND EXCLUSIVE REMEDY FOR DAMAGES FOR ANY CLAIM OF ANY KIND WHATSOEVER, REGARDLESS OF THE LEGAL THEORY AND WHETHER ARISING IN TORT OR CONTRACT, SHALL NOT BE GREATER THAN THE ACTUAL PURCHASE PRICE OF THE PRODUCT FOR WHICH SUCH CLAIM IS MADE. IN NO EVENT SHALL LEDGLOW BE LIABLE TO PURCHASER FOR ANY SPECIAL, INDIRECT, INCIDENTAL, OR CONSEQUENTIAL DAMAGES OF ANY KIND INCLUDING, BUT NOT LIMITED TO, COMPENSATION, REIMBURSEMENT OR DAMAGES ON ACCOUNT OF THE LOSS OF PRESENT OR PROSPECTIVE PROFITS OR FOR ANY OTHER REASON WHATSOEVER.

GOVERNING LAW: This non-transferrable limited warranty shall be governed by the law of the State of New Jersey, U.S.A., and the United States of America, excluding their conflicts of laws principles. The courts of Camden County, New Jersey, shall have the exclusive jurisdiction over any legal action with respect to this warranty.

This limited warranty gives specific legal rights. You may also have other rights that may vary from state to state or from country to country. Some states or countries do not allow the exclusion or limitation of incidental or consequential damages, so the above limitations and exclusions may not apply to you. You are advised to consult applicable state or country laws for a full determination of rights.